



Mellanox DPDK Quick Start Guide

2.1_1.1

NOTE:

THIS HARDWARE, SOFTWARE OR TEST SUITE PRODUCT (“PRODUCT(S)”) AND ITS RELATED DOCUMENTATION ARE PROVIDED BY MELLANOX TECHNOLOGIES “AS-IS” WITH ALL FAULTS OF ANY KIND AND SOLELY FOR THE PURPOSE OF AIDING THE CUSTOMER IN TESTING APPLICATIONS THAT USE THE PRODUCTS IN DESIGNATED SOLUTIONS. THE CUSTOMER'S MANUFACTURING TEST ENVIRONMENT HAS NOT MET THE STANDARDS SET BY MELLANOX TECHNOLOGIES TO FULLY QUALIFY THE PRODUCT(S) AND/OR THE SYSTEM USING IT. THEREFORE, MELLANOX TECHNOLOGIES CANNOT AND DOES NOT GUARANTEE OR WARRANT THAT THE PRODUCTS WILL OPERATE WITH THE HIGHEST QUALITY. ANY EXPRESS OR IMPLIED WARRANTIES, INCLUDING, BUT NOT LIMITED TO, THE IMPLIED WARRANTIES OF MERCHANTABILITY, FITNESS FOR A PARTICULAR PURPOSE AND NON-INFRINGEMENT ARE DISCLAIMED. IN NO EVENT SHALL MELLANOX BE LIABLE TO CUSTOMER OR ANY THIRD PARTIES FOR ANY DIRECT, INDIRECT, SPECIAL, EXEMPLARY, OR CONSEQUENTIAL DAMAGES OF ANY KIND (INCLUDING, BUT NOT LIMITED TO, PAYMENT FOR PROCUREMENT OF SUBSTITUTE GOODS OR SERVICES; LOSS OF USE, DATA, OR PROFITS; OR BUSINESS INTERRUPTION) HOWEVER CAUSED AND ON ANY THEORY OF LIABILITY, WHETHER IN CONTRACT, STRICT LIABILITY, OR TORT (INCLUDING NEGLIGENCE OR OTHERWISE) ARISING IN ANY WAY FROM THE USE OF THE PRODUCT(S) AND RELATED DOCUMENTATION EVEN IF ADVISED OF THE POSSIBILITY OF SUCH DAMAGE.



Mellanox Technologies
350 Oakmead Parkway Suite 100
Sunnyvale, CA 94085
U.S.A.
www.mellanox.com
Tel: (408) 970-3400
Fax: (408) 970-3403

© Copyright 2015. Mellanox Technologies. All Rights Reserved.

Mellanox®, Mellanox logo, BridgeX®, ConnectX®, Connect-IB®, CoolBox®, CORE-Direct®, GPUDirect®, InfiniBridge®, InfiniHost®, InfiniScale®, Kotura®, Kotura logo, Mellanox Connect. Accelerate. Outperform logo, Mellanox Federal Systems®, Mellanox Open Ethernet®, Mellanox Virtual Modular Switch®, MetroDX®, MetroX®, MLNX-OS®, Open Ethernet logo, PhyX®, ScalableHPC®, SwitchX®, TestX®, The Generation of Open Ethernet logo, UFM®, Virtual Protocol Interconnect®, Voltaire® and Voltaire logo are registered trademarks of Mellanox Technologies, Ltd.

CyPU™, ExtendX™, FabricIT™, FPGA Direct™, HPC-X™, Mellanox Care™, Mellanox CloudX™, Mellanox NEO™, Mellanox Open Ethernet™, Mellanox PeerDirect™, NVMeDirect™, StPU™, Spectrum™, Switch-IB™, Unbreakable-Link™ are trademarks of Mellanox Technologies, Ltd.

All other trademarks are property of their respective owners.

Table of Contents

Document Revision History	5
1 Overview	7
2 MLNX_DPDK Installation and Configuration	7
2.1 Installing ConnectX-3 and ConnectX-3 Pro.....	7
2.1.1 Bare Metal.....	7
2.1.2 KVM	8
2.2 Installing ConnectX-4 and ConnectX-4 LX.....	9
2.3 Configuring PMD Debug Mode.....	10
2.4 Sending and Receiving Jumbo Frames	10
2.5 Setting RX VLAN Filter on ConnectX-3.....	11
3 System Performance Configuration	12
3.1 General Settings	12
3.2 ConnectX-3 KVM Settings	14
4 Running DPDK Application with Mellanox Poll-Mode Driver	16
4.1 ConnectX®-3 / ConnectX®-3 Pro.....	16
4.2 ConnectX®-4 / ConnectX®-4 Lx	16
5 Sanity Check	17

List of Tables

Table 1: Document Revision History	5
Table 2: Reference Documents.....	6

Document Revision History

Table 1: Document Revision History

Revision	Description
2.1_1.1	<ul style="list-style-type: none">• Added ConnectX-4 settings in section General Settings.• Updated ConnectX-4 examples in section ConnectX®-4/ ConnectX®-4 Lx
	Major restructure due to ConnectX-4/ConnectX-4 Lx support.
2.0_2.8.4	Initial Release

Related Documents

The following table lists the documents referenced in this User Manual.

Table 2: Reference Documents

Document Name	Description
Mellanox OFED Linux Release Notes	Describes the new features and changes of the latest MLNX_OFED release.
Mellanox OFED Linux User Manual	Provides general information on the installation, configuration, management and maintenance of the software and hardware of VPI (InfiniBand, Ethernet) adapter cards.
Mellanox DPDK Release Notes	Describes the new features and changes of the latest Mellanox DPDK

1 Overview

This is the Quick Start Guide for mlx4 and mlx5 DPDK Poll-Mode Driver (PMD) for Mellanox ConnectX®-3/ConnectX®-3 Pro and ConnectX®-4/ConnectX®-4 Lx Ethernet adapters.

2 MLNX_DPDK Installation and Configuration

2.1 Installing ConnectX-3 and ConnectX-3 Pro

2.1.1 Bare Metal

1. Install MLNX_OFED v3.1-x.x.x.

MLNX_OFED 3.0-x.x.x can be downloaded from Mellanox site:

http://www.mellanox.com/page/products_dyn?product_family=26&mtag=linux

2. Verify that ConnectX-3/ConnectX-3 Pro firmware is **2.35.5100** (Use `ibstat` command).
3. Set all the ports to Ethernet.

```
connectx_port_config
```

and follow the instructions on the screen.

For further instructions on how to run the script, please refer to the MLNX_OFED User Manual.

4. Add the following line to `/etc/modprobe.d/mlx4_core.conf`.

```
options mlx4_core log_num_mgm_entry_size=-7
```



NOTE: If VLAN filtering is used, set `log_num_mgm_entry_size=-1`.



NOTE: Please be aware, performance penalty can occur in this case.

5. Restart MLNX_OFED.

```
/etc/init.d/openib restart
```

6. Extract the package `MLNX_DPDK-2.1_1.1.tar.gz`

The default mlx4 configuration in `config/common_linuxapp` is the following:

```
#  
# Compile burst-oriented Mellanox ConnectX-3 (MLX4) PMD  
#  
CONFIG_RTE_LIBRTE_MLX4_PMD=y  
CONFIG_RTE_LIBRTE_MLX4_DEBUG=n
```

```
CONFIG_RTE_LIBRTE_MLX4_SGE_WR_N=1
CONFIG_RTE_LIBRTE_MLX4_MAX_INLINE=0
CONFIG_RTE_LIBRTE_MLX4_TX_MP_CACHE=8
CONFIG_RTE_LIBRTE_MLX4_SOFT_COUNTERS=1
```

7. Compile DPDK.

```
make install T=x86_64-native-linuxapp-gcc
```

For more advanced DPDK compilation options, please refer to dpu.org documentation:

http://www.dpdk.org/doc/guides/linux_gsg/index.html

8. Configure huge pages according to the NUMA the card is connected to

```
echo $PAGE_NUM >
/sys/devices/system/node/node$NUMA_NODE/hugepages/hugepages-
"$PAGE_SIZE"kB/nr_hugepages

mkdir -p /mnt/huge

HTLB_MOUNTED=$( mount | grep "type hugetlbfs" | wc -l)
if [ $HTLB_MOUNTED -eq 0 ]; then
    mount -t hugetlbfs hugetlb /mnt/huge
fi
```

2.1.2 KVM

2.1.2.1 KVM Hypervisor

1. Download MLNX_OFED 3.1-x.x.x.

MLNX_OFED 3.1-x.x.x can be downloaded from Mellanox site:

http://www.mellanox.com/page/products_dyn?product_family=26&mtag=linux

2. Install MLNX_OFED v3.1-x.x.x and enable SR-IOV.

```
./mlnxofedinstall --enable-sriov -hypervisor
```

Please follow MLNX_OFED User Manual instructions how to enable SR-IOV.

3. Verify that ConnectX-3/ConnectX-3 Pro firmware is **2.35.5100** (Use `ibstat` command).

4. Add the following line to `/etc/modprobe.d/mlx4_core.conf`.

```
options mlx4_core log_num_mgm_entry_size=-7
```



NOTE: If VLAN filtering is used, set `log_num_mgm_entry_size=-1`.



NOTE: Please be aware, performance penalty can occur in this case.

5. Restart MLNX_OFED.

```
/etc/init.d/openibd restart
```

2.1.2.2 KVM Virtual Machine

1. Download MLNX_OFED 3.1-x.x.x.

MLNX_OFED 3.1-x.x.x can be downloaded from Mellanox site:

http://www.mellanox.com/page/products_dyn?product_family=26&mtag=linux

2. Install MLNX_OFED v3.1-x.x.x and enable the guest.

```
./mlnxofedinstall --guest
```

3. Extract the package MLNX_DPDK-2.1_1.1.tar.gz

4. The default mlx4 configuration in `config/common_linuxapp` is the following:

```
#
# Compile burst-oriented Mellanox ConnectX-3 (MLX4) PMD
#
CONFIG_RTE_LIBRTE_MLX4_PMD=y
CONFIG_RTE_LIBRTE_MLX4_DEBUG=n
CONFIG_RTE_LIBRTE_MLX4_SGE_WR_N=1
CONFIG_RTE_LIBRTE_MLX4_MAX_INLINE=0
CONFIG_RTE_LIBRTE_MLX4_TX_MP_CACHE=8
CONFIG_RTE_LIBRTE_MLX4_SOFT_COUNTERS=1
```

5. Compile DPDK.

```
make install T=x86_64-native-linuxapp-gcc
```

For more advanced DPDK compilation options, please refer to dpdk.org documentation:

http://www.dpdk.org/doc/guides/linux_gsg/index.html

6. Configure huge pages

```
echo $PAGE_NUM > /sys/devices/system/node/node0/hugepages/hugepages-
"$PAGE_SIZE"kB/nr_hugepages

mkdir -p /mnt/huge

HTLB_MOUNTED=$( mount | grep "type hugetlbfs" | wc -l)
if [ $HTLB_MOUNTED -eq 0 ]; then
    mount -t hugetlbfs hugetlb /mnt/huge
fi
```

2.2 Installing ConnectX-4 and ConnectX-4 LX

1. Download MLNX_OFED 3.1-x.x.x.

MLNX_OFED 3.1-x.x.x can be downloaded from Mellanox site:

http://www.mellanox.com/page/products_dyn?product_family=26&mtag=linux

2. Install MLNX_OFED v3.1-x.x.x.
3. Verify that ConnectX-4 firmware is **12.12.0780** and ConnectX-4 Lx firmware is **14.12.0780** (Use `ibstat` command).
4. Set all the ports to Ethernet.

```
mst start

mlxconfig -d <device> set LINK_TYPE_P1/2=1/2/3
* LINK_TYPE_P1=<1|2|3> , 1=Infiniband 2=Ethernet 3=VPI(auto-sense)
For example:
mlxconfig -d /dev/mst/mt4115_pciconf0 set LINK_TYPE_P1=2

mlxfwreset -d <device> reset
```

For further instructions on how to run the script, please refer to the MLNX_OFED User Manual.

5. Restart MLNX_OFED.

```
/etc/init.d/openib restart
```

6. Extract the package MLNX_DPDK-2.1_1.1.tar.gz

7. The default mlx5 configuration in config/common_linuxapp is the following:

```
#
# Compile burst-oriented Mellanox ConnectX-4 (MLX5) PMD
#
CONFIG_RTE_LIBRTE_MLX5_PMD=y
CONFIG_RTE_LIBRTE_MLX5_DEBUG=n
CONFIG_RTE_LIBRTE_MLX5_SGE_WR_N=1
CONFIG_RTE_LIBRTE_MLX5_MAX_INLINE=0
CONFIG_RTE_LIBRTE_MLX5_TX_MP_CACHE=8
CONFIG_RTE_LIBRTE_MLX5_SOFT_COUNTERS=1
```

8. Compile DPDK.

```
make install T=x86_64-native-linuxapp-gcc
```

For more advanced DPDK compilation options, please refer to dpdk.org documentation:

http://www.dpdk.org/doc/guides/linux_gsg/index.html

9. Configure huge pages according to the NUMA the card is connected to

```
echo $PAGE_NUM >
/sys/devices/system/node/node$NUMA_NODE/hugepages/hugepages-
"$PAGE_SIZE"kB/nr_hugepages

mkdir -p /mnt/huge

HTLB_MOUNTED=$( mount | grep "type hugetlbfs" | wc -l)
if [ $HTLB_MOUNTED -eq 0 ]; then
    mount -t hugetlbfs hugetlb /mnt/huge
fi
```

2.3 Configuring PMD Debug Mode

➤ *To enable Debug mode:*

1. Modify the config/common_linuxapp file.

- For ConnectX-3 PMD: CONFIG_RTE_LIBRTE_MLX4_DEBUG=y
- For ConnectX-4 PMD: CONFIG_RTE_LIBRTE_MLX5_DEBUG=y

2. Compile DPDK.

```
rm -rf x86_64-native-linuxapp-gcc
make install T=x86_64-native-linuxapp-gcc
```

2.4 Sending and Receiving Jumbo Frames

If the mbuf size is smaller than the MTU size and you need to use scattered mbuf.

1. Modify the config/common_linuxapp file.

- For ConnectX-3 PMD: CONFIG_RTE_LIBRTE_MLX4_SGE_WR_N=4
- For ConnectX-4 PMD: CONFIG_RTE_LIBRTE_MLX5_SGE_WR_N=4

2. Compile DPDK.

```
rm -rf x86_64-native-linuxapp-gcc
make install T=x86_64-native-linuxapp-gcc
```

3. Set the appropriate MTU using the `rte_eth_dev_set_mtu` API.

2.5 Setting RX VLAN Filter on ConnectX-3

1. Make sure that regular steering mode is configured.

```
cat /sys/module/mlx4_core/parameters/log_num_mgm_entry_size -1
```

2. Modify the `/etc/modprob.d/mlnx.conf` file if required and restart `MLNX_OFED`.
3. Configure VLAN interface on the port using standard Linux tools.
4. Add or remove VLAN using the `rte_eth_dev_vlan_filter()` DPDK API.

3 System Performance Configuration

3.1 General Settings

- Use the CPU near local NUMA node to which the PCIe adapter is connected, for better performance.

For Virtual Machines (VM), verify that the right CPU and NUMA node are pinned for the VM according to the above. If possible, connect you NIC near NUMA node 0

run `mst status -v` to identify the NUMA node to which the PCIe adapter is connected

```
mst status -v
MST modules:
-----
    MST PCI module loaded
    MST PCI configuration module loaded
PCI devices:
-----
DEVICE_TYPE          MST          PCI          RDMA
NET
ConnectX3Pro(rev:0)  /dev/mst/mt4103_pciconf0
ConnectX3Pro(rev:0)  /dev/mst/mt4103_pci_cr0    04:00.0    mlx4_0
net-eth4,net-eth5
```

- If more than one adapter is used, verify that both adapters are located on the same PCI bus (as each CPU socket on a Crown Pass platform manages its own PCI bus) in order to forward packets from one to the other without NUMA performance penalty.

- **ConnectX-3:**

- Verify the optimized steering mode is configured

```
cat /sys/module/mlx4_core/parameters/log_num_mgm_entry_size -7
```

- If not, modify `/etc/modprobe.d/mlx4_core.conf` and restart `MLNX_OFED`

- **ConnectX-4:**

- Make sure to set environment variable `MLX5_ENABLE_CQE_COMPRESSION=1`

```
MLX5_ENABLE_CQE_COMPRESSION=1 ./testpmd -c 0xe000 -n 4 --socket-
mem=0,2048 -- --port-numa-config=0,1,1,1 --socket-num=1 --burst=64 --
txd=1024 --rxd=256 --mbcache=512 --rxq=1 --txq=1 --nb-cores=2 --i
```

- **Check the Core Frequency**

Check that the output CPU frequency for each core is equal to the maximum supported and that all core frequencies are consistent.

- Check the maximum supported CPU frequency:

```
#cat /sys/devices/system/cpu/cpu*/cpufreq/cpuinfo_max_freq
```

- Check that the core frequencies are consistent

```
#cat /proc/cpuinfo | grep "cpu MHz"
```

- Check that the output frequencies are the same as the maximum supported

- Check the current CPU frequency to check whether it is configured to max available frequency:

```
#cat /sys/devices/system/cpu/cpu*/cpufreq/cpuinfo_cur_freq
```

When the following CPU frequency modules are loaded, CPU scaling is enabled, and you can improve performance by setting the scaling mode to performance:

- **Set the scaling mode to performance for every CPU**

```
# echo performance >
/sys/devices/system/cpu/cpu<cpunumber>/cpufreq/scaling_governor
```

For further information, please refer to Performance Tuning Guide for Mellanox Adapters

(http://www.mellanox.com/related-docs/prod_software/Performance_Tuning_Guide_for_Mellanox_Network_Adapters.pdf)

- **Verify that Max_Read_Req BIOS parameter is set to 4K**

To obtain the current setting for the Max_Read_Req BIOS parameter:

```
setpci -s <NIC BIOS address> 68.w
```

```
example:
setpci -s 21:00.0 68.w
5026
```

If the output is different than 5XXX, set it by:

```
setpci -s <NIC BIOS address> 68.w=5XXX
```

For example:

```
setpci -s 84:00.0 68.w
2026
Run: setpci -s 84:00.0 68.w=5026
```

- **Disable pause frames on all network interfaces managed by mlx4_en/mlx5_en**

```
lldpad stop
ethtool -A eth16 rx off tx off
```



NOTE: In certain systems, pause frames are used to increase performance.

- **Use 1Gb huge pages**

- **Hyper threading**

In certain DPDK application, enabling hyper threading results in better performance. For benchmarking purposes, it is recommended to disable hyper threading

- **Make sure that unnecessary System Management Interrupts (SMIs) are disabled**

SMI that are used for Power Monitoring and for Memory PreFailure Notification are recommended to be disabled. Please refer to your server provider guides for recommended platform tuning.

- **Isolate used cores**

Use `isolcpus` command for boot configuration.

For example, add the following to kernel boot parameters:

```
isolcpus=2,3
```

- **Disable kernel memory compaction**

```
echo never > /sys/kernel/mm/transparent_hugepage/defrag
echo never > /sys/kernel/mm/transparent_hugepage/enabled
echo 0 > /sys/kernel/mm/transparent_hugepage/khugepaged/defrag
sysctl -w vm.swappiness=0
sysctl -w vm.zone_reclaim_mode=0
```

- **Interrupts configuration**



NOTE: Interrupts configuration should be performed only if the needed performance was not achieved.

- Stop irqbalancer

```
service irqbalance stop
```

- Set all possible interrupts to different NUMA:

```
Example: echo '6-9' | sudo tee /proc/irq/*/smp_affinity_list
```

- Set NIC interrupts to same NUMA:

Example:

```
set_irq_affinity_cpulist.sh 0-1 ethX
```

- Set other NIC interrupts to different NUMA:

Example:

```
set_irq_affinity_cpulist.sh 6-9 ethY
```

3.2 ConnectX-3 KVM Settings

1. Make sure that Hypervisor kernel is 3.16 or newer (For example Ubuntu 14.10 or Fedora 20/21 can be used).
2. Configure boot with "iommu=pt".
3. Use 1G huge pages.
4. Make sure to allocate a VM on huge pages

Example:

qemu is started with the following commands:

```
umount /mnt/huge 2> /dev/null
mount -t hugetlbfs none /mnt/huge &&
echo 8192 > /sys/kernel/mm/hugepages/hugepages-2048kB/nr_hugepages &&

numactl --cpunodebind 1 --membind 1 -- \
qemu-system-x86_64 \
-smp 24 \
-m 4G \
-mem-path /mnt/huge \
-mem-prealloc \
-enable-kvm \
-cpu host \
-serial tcp::999,server,nowait \
-nographic \
-vga none \
- -device pci-assign,host=83:00.1 \
-device pci-assign,host=84:00.1 \
-drive snapshot=on,file=/opt/vm/ubuntu-14.04-template.qcow2 \
-drive file=/data/data.img
```

Since both adapters are installed on NUMA node 1 PCI slots (CPU socket 1), `*numactl` is used to bind `qemu` to CPU threads and memory from that node only, which makes a Virtual Machine without NUMA internally.

All its memory is allocated from huge pages in `/mnt/huge`.

- After loading VM, verify huge pages on your Hypervisor is used by VM:

```
cat /sys/devices/system/node/node<NUM>/hugepages/hugepages-<PAGE-  
SIZE>/free_hugepages
```

- Make sure to set CPU pining

For example if you run `qemu`:

```
(qemu) info cpus  
CPU #0: pc=0xffffffff81056306 (halted) thread_id=2719  
CPU #1: pc=0xffffffff81056306 (halted) thread_id=2720  
CPU #2: pc=0xffffffff81056306 (halted) thread_id=2723  
CPU #3: pc=0xffffffff81056306 (halted) thread_id=2724  
taskset -p 0x1 2719  
taskset -p 0x2 2720  
taskset -p 0x4 2723  
taskset -p 0x8 2724
```

4 Running DPDK Application with Mellanox Poll-Mode Driver

4.1 ConnectX®-3 / ConnectX®-3 Pro

Since mlx4 PMD is compiled statically with MLNX_DPDK 2.1, no special requirements are needed to run the application with mlx4 PMD.

For example:

```
./testpmd -c 0xe000 -n 4 --socket-mem=0,2048 -- --port-numa-config=0,1,1,1
--socket-num=1 --burst=64 --txd=256 --rxq=256 --mbcache=512 --rxq=1 --
txq=1 --nb-cores=2 --i
```

Specific PCI address can be used to specify the NIC:

```
./testpmd -c 0xe000 -n 4 -w 0000:08:00.0 --socket-mem=0,2048 -- --port-numa-
config=0,1,1,1 --socket-num=1 --burst=64 --txd=256 --rxq=256 --mbcache=512
--rxq=1 --txq=1 --nb-cores=2 --i
```



NOTE: In ConnectX-3 NICs, a single PCI address represents 2 ports.

When running bi-directional traffic, for better performance, use the receive-inline feature that can be enabled by the env variable `MLX4_INLINE_RECV_SIZE`.

Example: for 64B messages

```
MLX4_INLINE_RECV_SIZE=64 ./testpmd -c 0xe000 -n 4 --socket-mem=0,2048 -- --
port-numa-config=0,1,1,1 --socket-num=1 --burst=64 --txd=256 --rxq=256 --
mbcache=512 --rxq=1 --txq=1 --nb-cores=2 --i
```

4.2 ConnectX®-4 / ConnectX®-4 Lx

Since mlx5 PMD is compiled statically with MLNX_DPDK 2.1, no special requirements are needed to run the application with mlx5 PMD.

For example:

```
MLX5_ENABLE_CQE_COMPRESSION=1 ./testpmd -c 0xe000 -n 4 --socket-mem=0,2048
-- --port-numa-config=0,1,1,1 --socket-num=1 --burst=64 --txd=1024 --
rxq=256 --mbcache=512 --rxq=1 --txq=1 --nb-cores=2 --i
```

Specific PCI address can be used to specify NIC's ports:

```
MLX5_ENABLE_CQE_COMPRESSION=1 ./testpmd -c 0xe000 -n 4 -w 0000:08:00.0 -w
0000:08:00.1 --socket-mem=0,2048 -- --port-numa-config=0,1,1,1 --socket-
num=1 --burst=64 --txd=256 --rxq=256 --mbcache=512 --rxq=1 --txq=1 --nb-
cores=2 --i
```



NOTE: In ConnectX-4 NICs, a PCI address represents each port.

Some ConnectX-4 Lx cards are single port cards. To run testpmd fwd test on one port:

```
MLX5_ENABLE_CQE_COMPRESSION=1 ./testpmd -c 0xe000 -n 4 -w 0000:08:00.0 --
socket-mem=0,2048 -- --port-numa-config=0,1,1,1 --socket-num=1 --port-
topology=chained --burst=64 --txd=1024 --rxq=256 --mbcache=512 --rxq=1 --
txq=1 --nb-cores=2 --i
```

5 Sanity Check

Provided that all software components have been successfully installed and at least one ConnectX® adapter is present in the host system, run testpmd to test PMD.

These examples assume that there is a host with two dual port adapters that:

- First port of each NIC is linked to another similar host
- Second port of each NIC is linked with each other

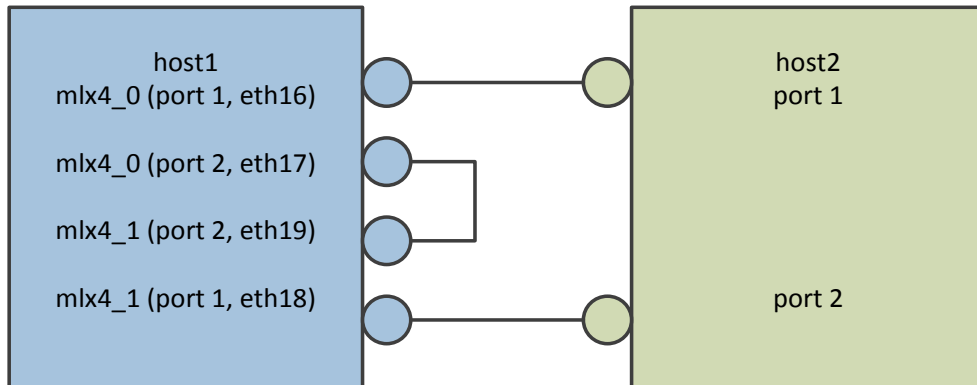

1. Run `*testpmd*` interactively from the DPDK build tree (for more information about its command-line options, please refer to its documentation: http://www.dpdk.org/doc/guides/testpmd_app Ug/index.html):

```

root# ~/DPDK/x86_64-native-linuxapp-gcc/app/test-pmd/testpmd -c
0xf000f000 -n 4 -d -- -i
EAL: Detected lcore 0 as core 0 on socket 0
EAL: Detected lcore 1 as core 1 on socket 0
EAL: Detected lcore 2 as core 2 on socket 0
EAL: Detected lcore 3 as core 3 on socket 0
EAL: Detected lcore 4 as core 4 on socket 0
[...]
EAL: Detected lcore 27 as core 3 on socket 1
EAL: Detected lcore 28 as core 4 on socket 1
EAL: Detected lcore 29 as core 5 on socket 1
EAL: Detected lcore 30 as core 6 on socket 1
EAL: Detected lcore 31 as core 7 on socket 1
EAL: Support maximum 64 logical core(s) by configuration.
EAL: Detected 32 lcore(s)
EAL: cannot open VFIO container, error 2 (No such file or directory)
EAL: VFIO support could not be initialized
EAL: Setting up memory...
EAL: Ask a virtual area of 0x6400000 bytes
EAL: Virtual area found at 0x7f15fd600000 (size = 0x6400000)
EAL: Ask a virtual area of 0x200000 bytes
[...]
EAL: PCI device 0000:83:00.0 on NUMA socket 1
EAL: probe driver: 15b3:1007 librte_pmd_mlx4
PMD: librte_pmd_mlx4: PCI information matches, using device "mlx4_0"
(VF: false)
PMD: librte_pmd_mlx4: 2 port(s) detected
PMD: librte_pmd_mlx4: bad state for port 1: "down" (1)
PMD: librte_pmd_mlx4: port 1 MAC address is 00:02:c9:b5:b7:50
PMD: librte_pmd_mlx4: bad state for port 2: "down" (1)
PMD: librte_pmd_mlx4: port 2 MAC address is 00:02:c9:b5:b7:51
EAL: PCI device 0000:84:00.0 on NUMA socket 1
EAL: probe driver: 15b3:1007 librte_pmd_mlx4
PMD: librte_pmd_mlx4: PCI information matches, using device "mlx4_1"
(VF: false)

```

```

PMD: librte_pmd_mlx4: 2 port(s) detected
PMD: librte_pmd_mlx4: bad state for port 1: "down" (1)
PMD: librte_pmd_mlx4: port 1 MAC address is 00:02:c9:b5:ba:b0
PMD: librte_pmd_mlx4: bad state for port 2: "down" (1)
PMD: librte_pmd_mlx4: port 2 MAC address is 00:02:c9:b5:ba:b1
Interactive-mode selected
Configuring Port 0 (socket 0)
PMD: librte_pmd_mlx4: 0x7f35e0: TX queues number update: 0 -> 1
PMD: librte_pmd_mlx4: 0x7f35e0: RX queues number update: 0 -> 1
Port 0: 00:02:C9:B5:B7:50
Configuring Port 1 (socket 0)
PMD: librte_pmd_mlx4: 0x7f3620: TX queues number update: 0 -> 1
PMD: librte_pmd_mlx4: 0x7f3620: RX queues number update: 0 -> 1
Port 1: 00:02:C9:B5:B7:51
Configuring Port 2 (socket 0)
PMD: librte_pmd_mlx4: 0x7f3660: TX queues number update: 0 -> 1
PMD: librte_pmd_mlx4: 0x7f3660: RX queues number update: 0 -> 1
Port 2: 00:02:C9:B5:BA:B0
Configuring Port 3 (socket 0)
PMD: librte_pmd_mlx4: 0x7f36a0: TX queues number update: 0 -> 1
PMD: librte_pmd_mlx4: 0x7f36a0: RX queues number update: 0 -> 1
Port 3: 00:02:C9:B5:BA:B1
Checking link statuses...
Port 0 Link Up - speed 10000 Mbps - full-duplex
Port 1 Link Up - speed 40000 Mbps - full-duplex
Port 2 Link Up - speed 10000 Mbps - full-duplex
Port 3 Link Up - speed 40000 Mbps - full-duplex
Done
testpmd>

```

The following commands are typed from the *testpmd* interactive prompt.

1. Check port status:

```

testpmd> show port info all
***** Infos for port 0 *****
MAC address: 00:02:C9:B5:B7:50
Connect to socket: 0
memory allocation on the socket: 0
Link status: up
Link speed: 10000 Mbps
Link duplex: full-duplex
Promiscuous mode: enabled
Allmulticast mode: disabled
Maximum number of MAC addresses: 128
Maximum number of MAC addresses of hash filtering: 0
VLAN offload:
  strip on
  filter on
  qinq(extend) off

***** Infos for port 1 *****
MAC address: 00:02:C9:B5:B7:51
Connect to socket: 0
memory allocation on the socket: 0
Link status: up
Link speed: 40000 Mbps
Link duplex: full-duplex
Promiscuous mode: enabled
Allmulticast mode: disabled
Maximum number of MAC addresses: 128
Maximum number of MAC addresses of hash filtering: 0
VLAN offload:
  strip on
  filter on
  qinq(extend) off

```

```

***** Infos for port 2 *****
MAC address: 00:02:C9:B5:BA:B0
Connect to socket: 0
memory allocation on the socket: 0
Link status: up
Link speed: 10000 Mbps
Link duplex: full-duplex
Promiscuous mode: enabled
Allmulticast mode: disabled
Maximum number of MAC addresses: 128
Maximum number of MAC addresses of hash filtering: 0
VLAN offload:
  strip on
  filter on
  qinq(extend) off

***** Infos for port 3 *****
MAC address: 00:02:C9:B5:BA:B1
Connect to socket: 0
memory allocation on the socket: 0
Link status: up
Link speed: 40000 Mbps
Link duplex: full-duplex
Promiscuous mode: enabled
Allmulticast mode: disabled
Maximum number of MAC addresses: 128
Maximum number of MAC addresses of hash filtering: 0
VLAN offload:
  strip on
  filter on
  qinq(extend) off
testpmd>

```

2. Start IO forwarding between ports 1 and 3. The `*tx_first*` argument tells
3. `*testpmd*` to send a single packet burst which will be always forwarded by both ports:

```

testpmd> set fwd io
Set io packet forwarding mode
testpmd> set portlist 1,3
previous number of forwarding ports 4 - changed to number of
configured ports 2
testpmd> start tx_first
io packet forwarding - CRC stripping disabled - packets/burst=32
nb forwarding cores=1 - nb forwarding ports=2
RX queues=1 - RX desc=128 - RX free threshold=0
RX threshold registers: pthresh=8 hthresh=8 wthresh=0
TX queues=1 - TX desc=512 - TX free threshold=0
TX threshold registers: pthresh=32 hthresh=0 wthresh=0
TX RS bit threshold=0 - TXQ flags=0x0
testpmd>

```

4. Display `*testpmd*` port statistics:

```

testpmd> show port stats all

##### NIC statistics for port 0 #####
RX-packets: 0          RX-missed: 0          RX-bytes: 0
RX-badcrc: 0          RX-badlen: 0          RX-errors: 0
RX-nobuf: 0
TX-packets: 0          TX-errors: 0          TX-bytes: 0
#####

##### NIC statistics for port 1 #####
RX-packets: 60800584   RX-missed: 0          RX-bytes: 3891239534
RX-badcrc: 0          RX-badlen: 0          RX-errors: 0
RX-nobuf: 0
TX-packets: 61146609   TX-errors: 0          TX-bytes: 3913382976
#####

```

```
##### NIC statistics for port 2 #####
RX-packets: 0          RX-missed: 0          RX-bytes: 0
RX-badcrc: 0          RX-badlen: 0          RX-errors: 0
RX-nobuf: 0
TX-packets: 0          TX-errors: 0          TX-bytes: 0
#####

##### NIC statistics for port 3 #####
RX-packets: 61146920  RX-missed: 0          RX-bytes: 3913402990
RX-badcrc: 0          RX-badlen: 0          RX-errors: 0
RX-nobuf: 0
TX-packets: 60800953  TX-errors: 0          TX-bytes: 3891262080
#####
testpmd>
```

5. Stop forwarding:

```
testpmd> stop
Telling cores to stop...
Waiting for lcores to finish...

----- Forward statistics for port 1 -----
RX-packets: 78238689  RX-dropped: 0          RX-total: 78238689
TX-packets: 78681769  TX-dropped: 0          TX-total: 78681769
-----

----- Forward statistics for port 3 -----
RX-packets: 78681737  RX-dropped: 0          RX-total: 78681737
TX-packets: 78238721  TX-dropped: 0          TX-total: 78238721
-----

+++++ Accumulated forward statistics for all ports+++++
RX-packets: 156920426  RX-dropped: 0          RX-total: 156920426
TX-packets: 156920490  TX-dropped: 0          TX-total: 156920490
+++++

Done.
testpmd>
```

6. Exit testpmd.

```
testpmd> quit
Stopping port 0...done
Stopping port 1...done
Stopping port 2...done
Stopping port 3...done
bye...
root#
```