



BlueField[®] Reference Platform



Powerful & Flexible Reference Platform for a Wide Range of Applications Including Storage, Networking and Machine Learning

Today's network technologies drive OEMs to seek innovative, scalable and cost effective designs for dealing with the exponential growth of data. The Mellanox BlueField Reference Platform provides a multi-purpose fully-programmable hardware environment for evaluation, development and running of software solutions, reducing time-to-market and increasing product development and runtime efficiency.

The reference platform delivers all the features of the BlueField SoC in convenient form factors, making it ideal for a range of software solutions, for the most demanding markets. Features include two 100Gb/s Ethernet or InfiniBand interfaces, a 16-core BlueField processor, up to 512GB of RDIMM DDR4 memory, two PCIe x16 slots, and an NVMe-ready midplane for SSD connectivity.

BLUEFIELD PLATFORM FOR STORAGE APPLIANCES

Today's fast storage technologies drive storage OEMs to seek innovative, scalable and cost effective designs for their applications. Powered by the BlueField SoC, the BlueField 2U Reference Platform offers a unique combination of on-board capabilities and NVMe-readiness, creating an ideal environment for storage appliance development.

Platform Highlights

- Leverages the processing power of Arm[®] cores for storage applications such as All-Flash Arrays using NVMe-oF, Ceph, Lustre, iSCSI/TCP offload, Flash Translation Layer, RAID/Erasure coding, data compression/decompression, and deduplication.
- In high-performance storage arrays, BlueField serves as the system's main CPU, handling storage controller tasks and traffic termination.
- Provides up to 16 front-mounted 2.5" disk drive bays that are routed to an NVMe-ready midplane within the enclosure. The system can be configured as a storage JBOF with 16 drives using PCIe Gen 3.0 x2, or 8 drives with PCIe Gen 3.0 x4 lanes.

BLUEFIELD PLATFORM FOR MACHINE LEARNING

The BlueField 2U Reference Platform supports connectivity of up to 2 GPUs via its PCIe x16 Gen 3.0 interface, providing cost effective and integrative solutions for Machine Learning appliances. By utilizing RDMA and RoCE technology, the BlueField network controller data path hardware delivers low latency and high throughput with near-zero CPU cycles.

The platform also offers GPUDirect[®] RDMA technology, enabling the most efficient data exchange between GPUs and with the Mellanox high speed interconnect, optimizing real-time analytics and data insights.

HIGHLIGHTS

BENEFITS

- Powerful reference platform in a convenient 1U or 2U 19" box
- Enables evaluation, development and running of software solutions in real-world environments
- Easy to use
- 2U reference platform
 - Storage controller platform
 - NVMe-ready for storage applications
 - Support for up to sixteen 2.5" SSD bays
 - Option to add GPU cards for Machine Learning programmability
- 1U reference platform
 - Network appliance for high performance cloud SW solutions

FEATURES

- BlueField SoC
 - 16 Arm cores on-board
 - 32-lane PCIe switch
 - Two 100Gb/s Virtual Protocol Interconnect[®] network interfaces (InfiniBand and Ethernet)
- PCIe Gen 3.0/4.0 support
- Integrated BMC
- 32GB eMMC Flash memory for software

2U REFERENCE PLATFORM FEATURES

Enclosure Specifications

- 2U 19"
- ATX form factor motherboard
- BlueField SoC with 16 Armv8 A72 cores (64-bit)
- Two internal x16 PCIe Gen3.0/4.0 expansion connectors
- Dual-port ConnectX-5 Virtual Protocol Interconnect® (VPI) interface
 - Ethernet: 40/50/100GbE QSFP ports
 - InfiniBand: FDR/EDR QSFP ports
 - 10/25Gb/s available with QSA28

- Two PCIe risers enabling 2.5" NVMe SSD disk support
 - 8 x PCIe Gen3 x4 lanes
 - 16 x PCIe Gen3 x2 lanes
- 1 x 850W FRU power supply
- Integrated BMC
- 32GB eMMC Flash memory for software
- 3 x 80mm fan cartridges

DRAM DIMM Support

- 4 sockets for DRAM DIMMs
- Up to 512GB total memory
- NVDIMM-N Support

1U REFERENCE PLATFORM FEATURES

Enclosure Specifications

- 1U 19"
- ATX form factor motherboard
- BlueField SoC with 16 Armv8 A72 cores (64-bit)
- One internal x16 PCIe Gen3.0 expansion connector
- Dual-port ConnectX-5 Virtual Protocol Interconnect® (VPI) interface
 - Ethernet: 40/50/100GbE QSFP ports
 - InfiniBand: FDR/EDR QSFP ports
 - 10/25Gb/s available with QSA28
- 1x 400W power supply
- Integrated BMC

- 32GB eMMC Flash memory for software
- 3 x 80mm fan cartridges

DRAM DIMM Support

- 4 sockets for DRAM DIMMs
- Up to 512GB total memory
- NVDIMM-N Support

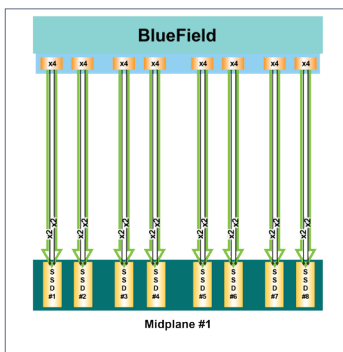

Figure 1. 8 SSD Configuration (2U platform)

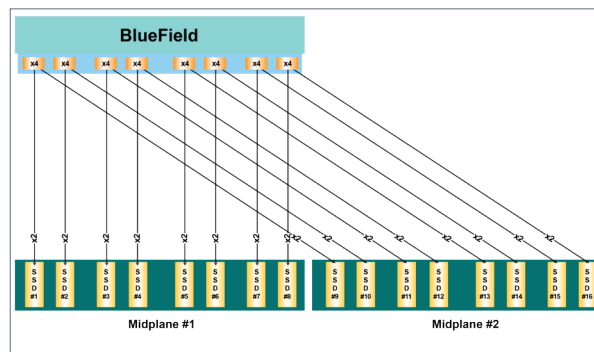

Figure 2. 16 SSD Configuration (2U platform)



Figure 3: 2U Reference Platform

NVME-READY MIDPLANE

A modular chassis midplane supports up to eight 2.5" SSDs, which can be duplicated to 16 SSDs. The midplane also supports hot swappable SSD cards, an I²C switch to enable connectivity of the SMBUS from the platform Baseboard Management Controller (BMC) to each SSD, and an on-board clock generator/buffer.

SOFTWARE SUPPORT

The BlueField Reference Platform comes pre-installed with a UEFI-based bootloader and BlueOS, a Linux reference distribution targeted at BlueField-based embedded systems. Based on the Yocto Project Poky distribution, BlueOS is highly customizable for meeting specific Linux distribution requirements through the OpenEmbedded Build System. Yocto produces

an SDK with an extremely flexible cross-build environment, ideal for building and running applications seamlessly for the Arm BlueField target system, on any x86 server running any Linux distribution. Mellanox OFED and NVMe-oF support is installed by default. The reference platform also provides a BMC running OpenBMC to manage the entire system. Note: Reference platform customers can run the Linux distribution of their choice.

Table 1 - Part Numbers and Descriptions

Product Family	OPN	Description
BF1200	MBE1200A-BN1	2U BlueField Reference Platform, BlueField E-Series, Crypto disabled. A storage controller platform with option for up to 16 SSDs. (SSDs are not included.)
	MBE1200A-BC1	2U BlueField Reference Platform, BlueField E-Series, Crypto enabled. A storage controller platform with option for up to 16 SSDs. (SSDs are not included.)
	MBE1201A-BN1	2U BlueField Reference Platform, BlueField P-Series, Crypto disabled. A storage controller platform with option for up to 16 SSDs. (SSDs are not included.)
	MBE1201A-BC1	2U BlueField Reference Platform, BlueField P-Series, Crypto enabled. A storage controller platform with option for up to 16 SSDs. (SSDs are not included.)
BF1100	MBE1100A-BN1	1U BlueField Reference Platform, BlueField E-Series, Crypto disabled. A network appliance platform.
	MBE1100A-BC1	1U BlueField Reference Platform, BlueField E-Series, Crypto enabled. A network appliance platform.

Support

For information about Mellanox support packages, please contact your Mellanox Technologies sales representative or visit our [Support Index page](#).